

Pole	Col.	Sec.	Cross	Function
A2	BLACK	0.35	X1/C	OUTLET BAR SGN
A3	ORANGE-BLACK	0.5	X2/2	FUEL LEVEL
B1	RED	1	X6/1	15/54
B2	BROWN	0.35	X1/B	+15 OUTLET BAR
B3	ORANGE	0.5	X2/1	RESERVE
B4	BROWN	0.5	X5/1	+15/54
B5	WHITE	0.5	X5/3	FLOW
C3	GREY	0.5	X2/3	FUEL GND
C4	BLUE-WHITE	0.5	X3/1	P. OIL
C5	GREY	0.5	X5/4	S_GND
C7	BLUE	0.5	X5/2	FLOWMETER

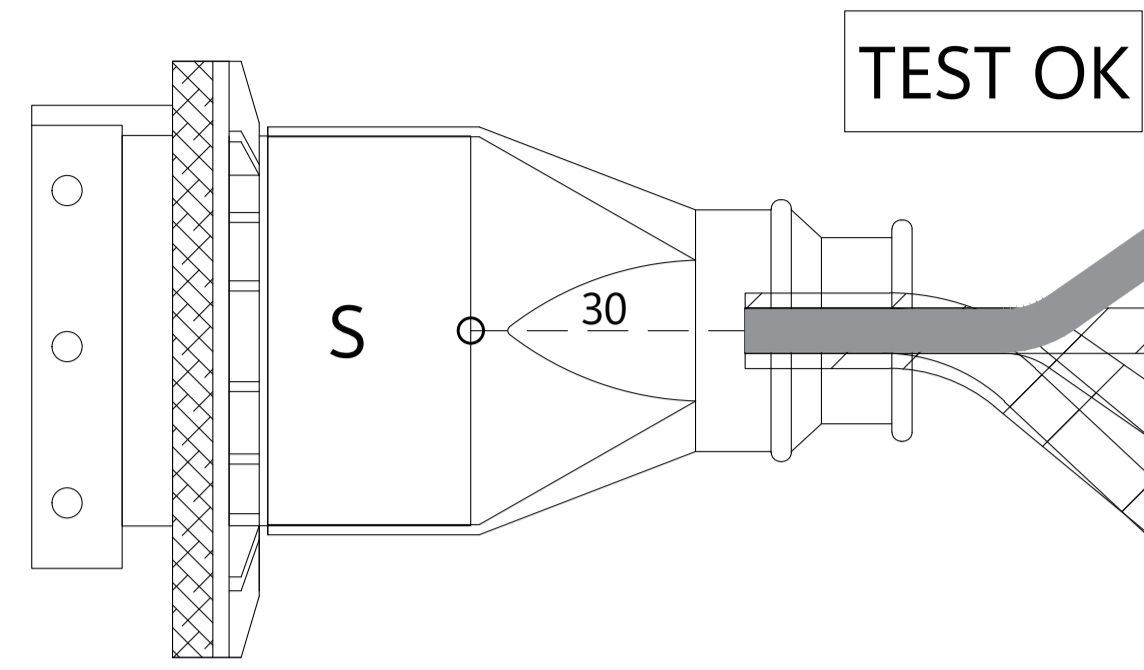

TEST OK

30

1600

1300

2600

1000

100

100

2600

100

100

100

100

100

100

100

100

100

100

100

100

100

100

100

100

100

100

100

100

100

100

100

100

100

100

100

100

100

100

100

100

100

100

100

100

100

100

100

100

100

100

100

100

100

100

100

100

100

100

100

100

100

100

100

100

100

100

100

100

100

100

100

100

100

100

100

100

100

100

100

100

100

100

100

100

100

100

100

100

100

100

100

100

100

100

100

100

100

100

100

100

100

100

100

100

100

100

100

100

100

100

100

100

100

100

100

100

100

100

100

100

100

100

100

100

100

100

100

100

100

100

100

100

100

100

100

100

100

100

100

100

100

100

100

100

100

100

100

100

100

100

100

100

100

100

100

100

100

100

100

100

100

100

100

100

100

100

100

100

100

100

100

100

100

100

100

100

100

100

100

100

100

100

100

100

100

100

100

100

100

100

100

100

100

100

100

100

100

100

100

100

100

100

100

100

100

100

100

100

100

100

100

100

100

100

100

100

100

100

100

100

100

100

100

100

100

100

100

100

100

100

100

100

100

100

100

100

100

100

100

100

100

100

100

100

100

100

100

100

100

100

100

100

100

100

100

100

100

100

100

100

100

100

100

100

100

100

100

100

100

100

100

100

100

100

100

100